

PACKAGING PLANT COLOURS:  
 a) ROLLER CONVEYOR FRAME / ROLLERS: 989-  
 WHITE COLD GALVANIZING  
 b) MACHINES:  
 Frame parts: RAL 7032 GRAY;  
 Moving parts: RAL 1021 YELLOW;  
 c) SAFETY NET PANEL, GATES and POLES:  
 RAL 9005 BLACK  
 d) CONTROL PANELS: RAL 7032 GRAY

N.B. FOR FUTURE PALLET dim. 1150x1400-  
 IT'S NOT POSSIBLE STOVE UP  
 M2 pallet dim. 1150x1400

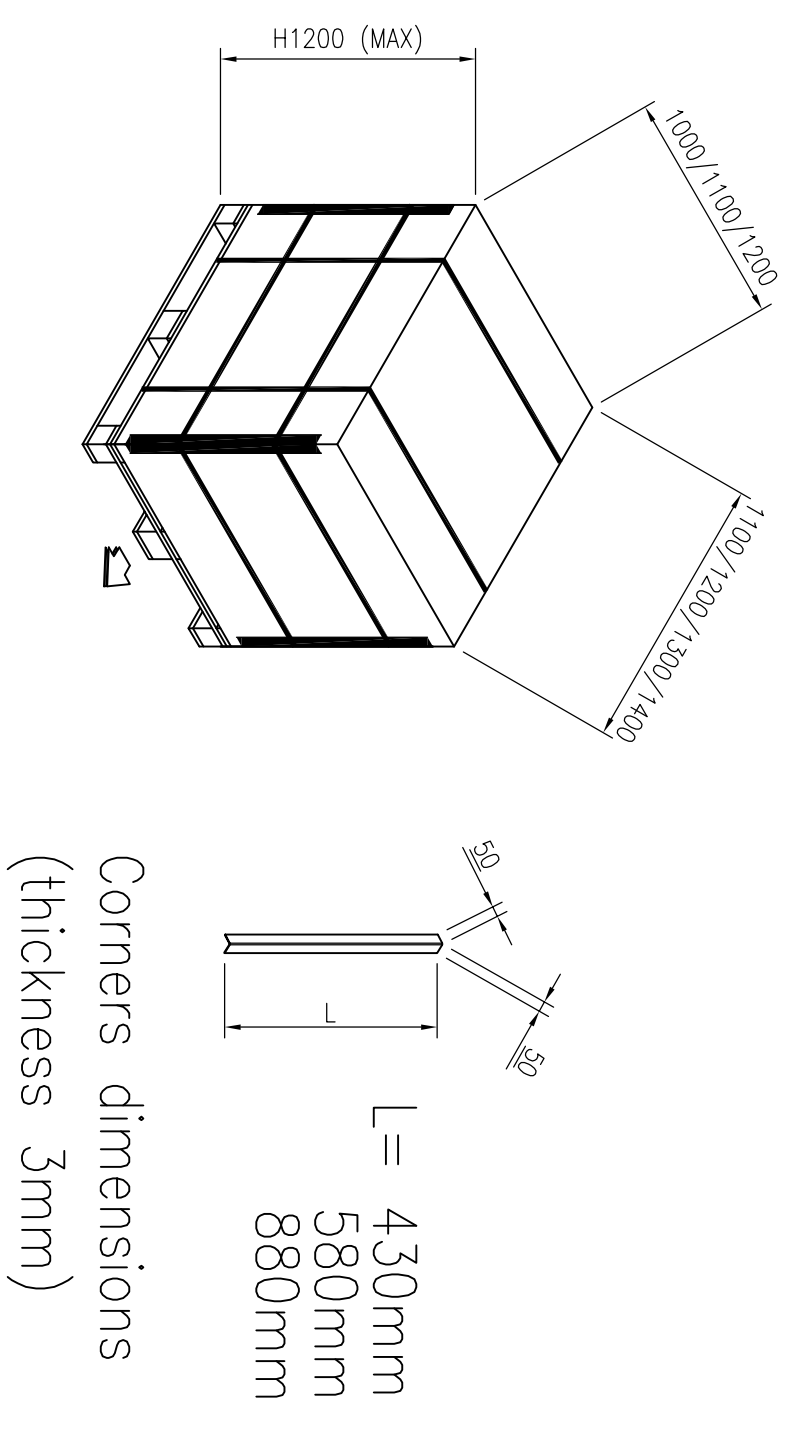
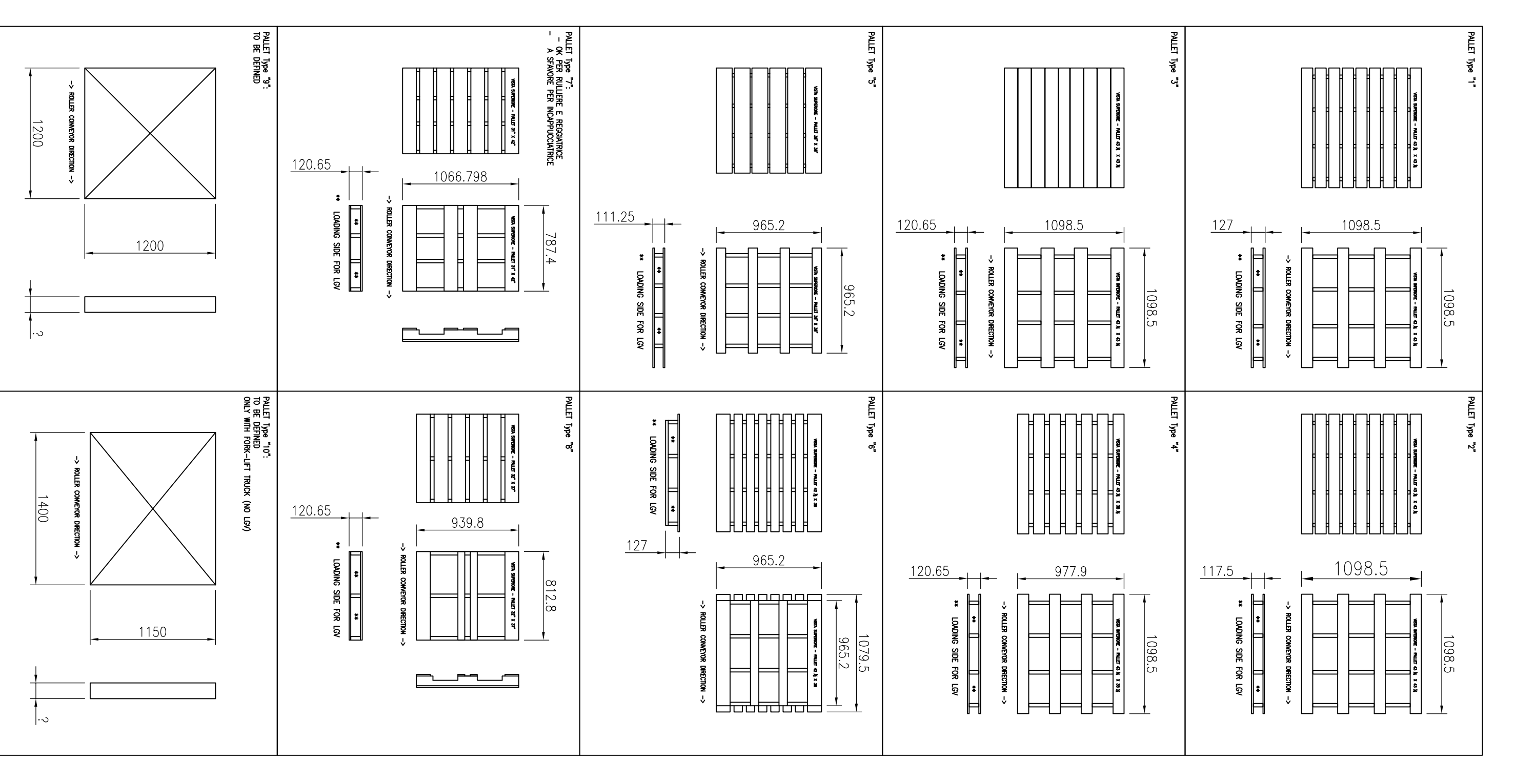
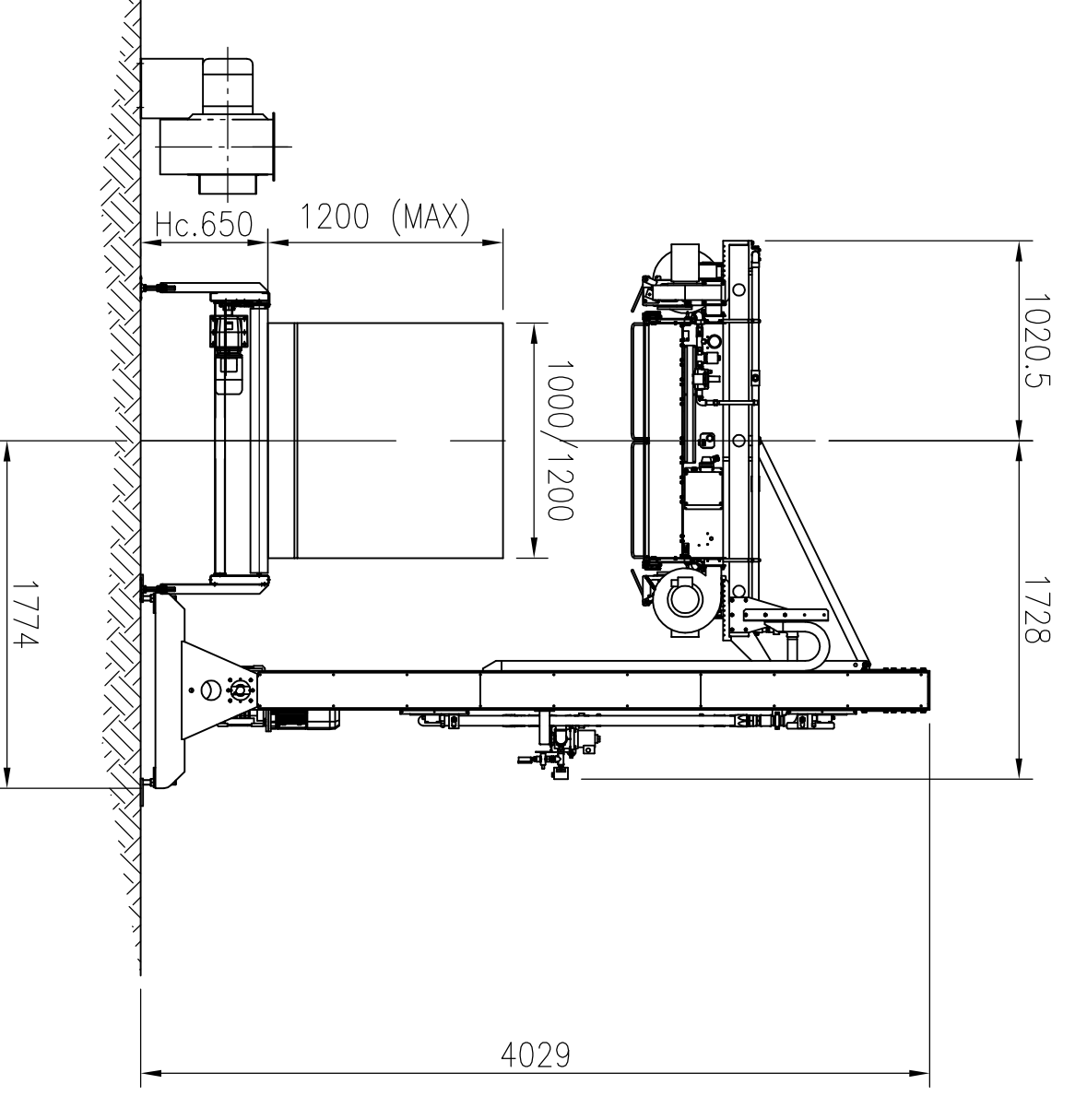
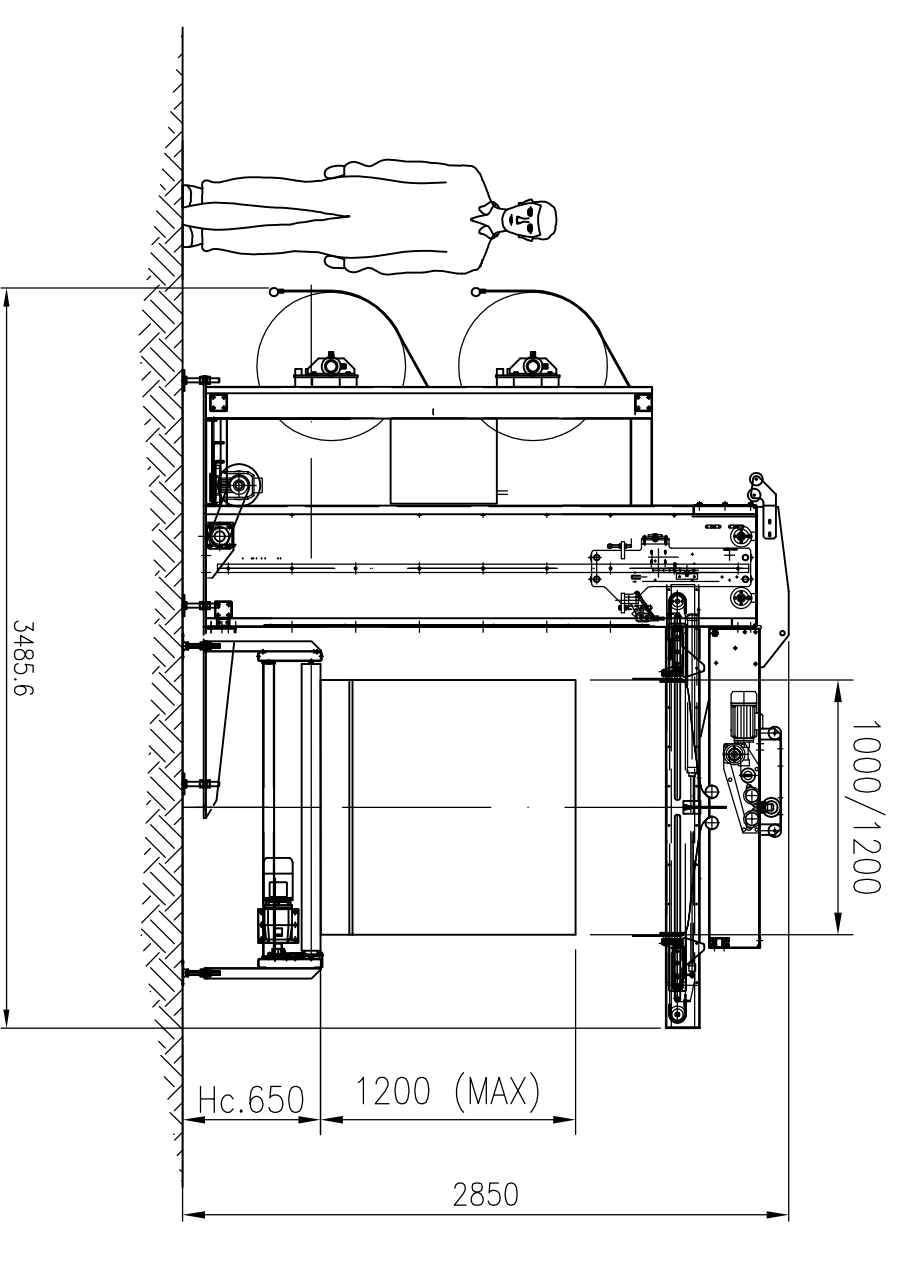
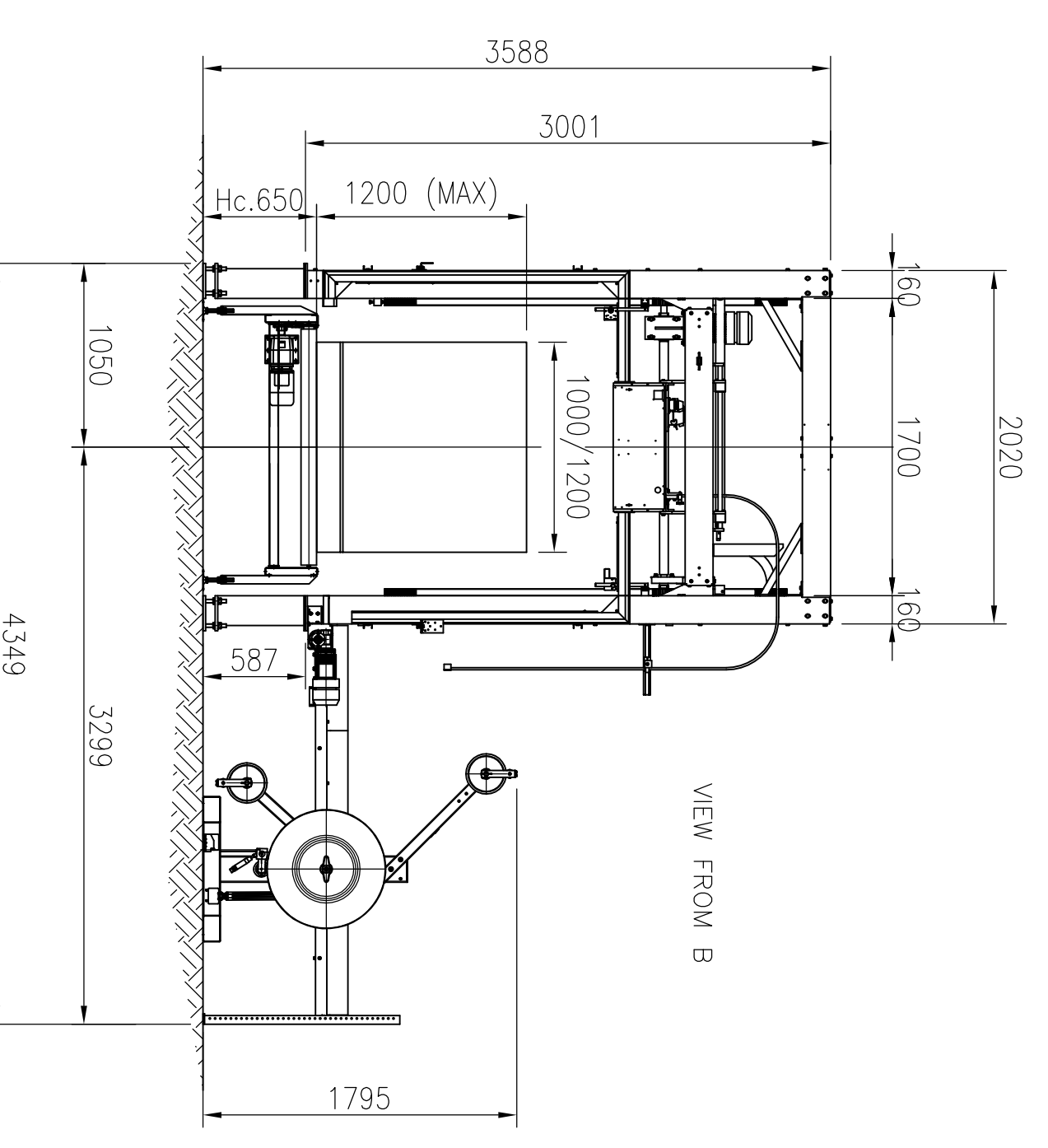
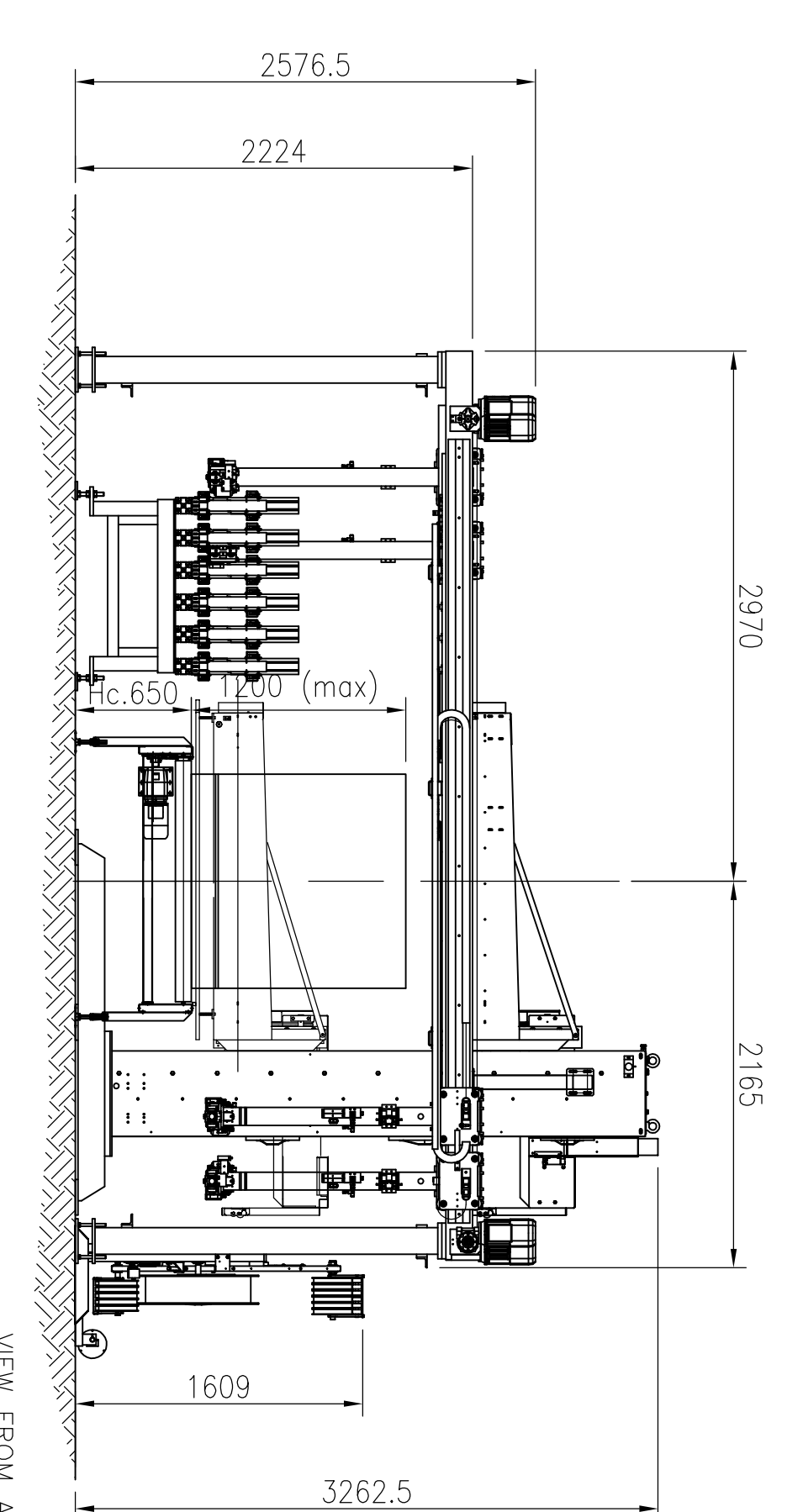
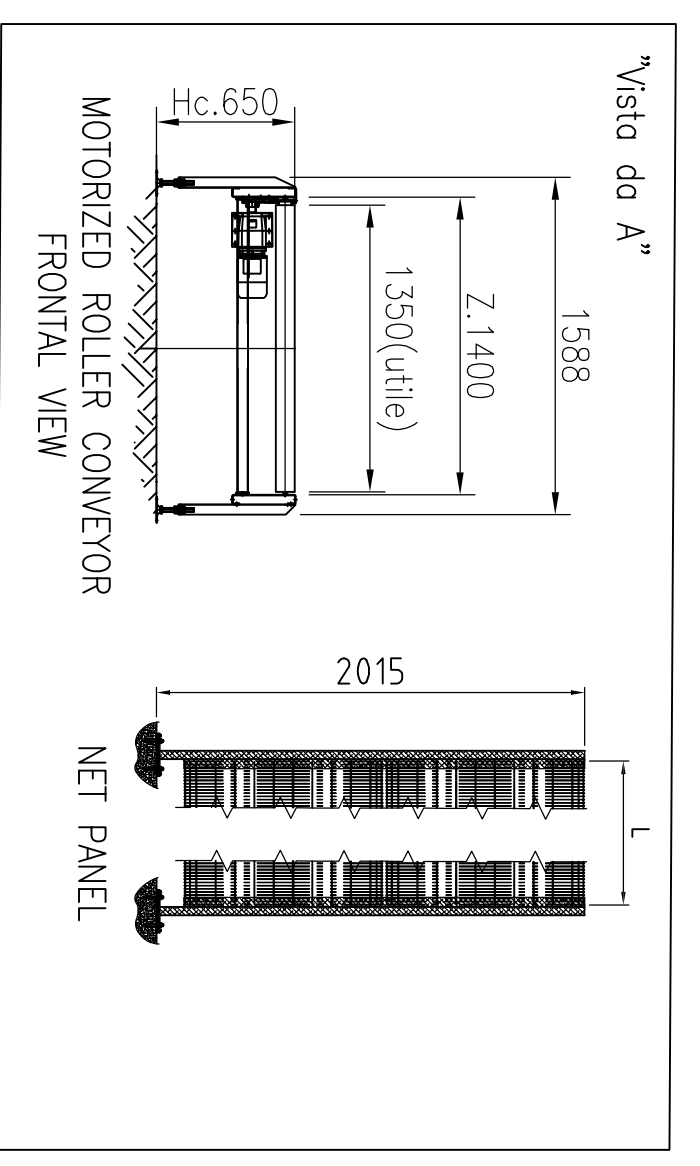
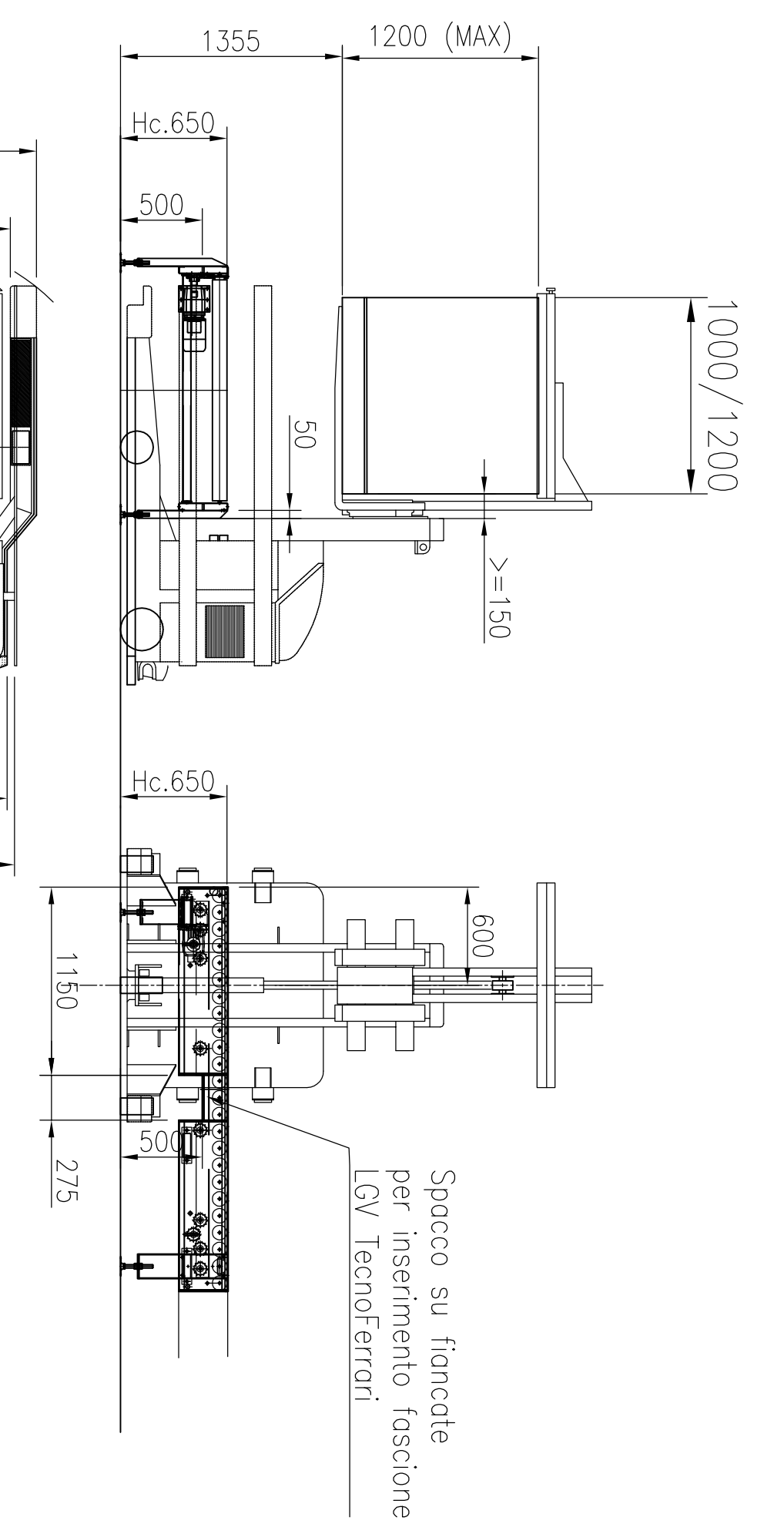

POS.	DATA	REVISIONE	DESCRIZIONE	DATA	REVISIONE	DESCRIZIONE	DATA	REVISIONE	DESCRIZIONE
22	03/10/2016	1	Approvato e modificato						
21	28/11/2016	1	Disegno						
20									
19									
18									
17									
16									
15									
14									
13									
12									
11									
10									
9									
8									
7									
6									
5									
4									
3									
2									
1									

**OMS Group**  
 CLIENT - CUSTOMER: DOTT. SOLIMIGNO  
 ORGANIZZAZIONE - RESORT/PRODOTTO: PACKING PLANT  
 SCALE: 1:25  
 DATA: 21/09/2016  
 DISTINZIONE N. REV: L160597 C